

Title	Iterative Spatial Demapping with Side Information for Three-way Relaying Systems
Author(s)	Anwar, Khoirul; Matsumoto, Tad
Citation	電子情報通信学会総合大会講演論文集, 2014年_通信(2): 293-293
Issue Date	2014-03
Type	Conference Paper
Text version	publisher
URL	http://hdl.handle.net/10119/12342
Rights	Copyright (C) 2014 The Institute of Electronics, Information and Communication Engineers (IEICE). Khoirul Anwar and Tad Matsumoto, 電子情報通信学会総合大会講演論文集, 2014年_通信(2), 2014, 293-293.
Description	

Iterative Spatial Demapping with Side Information for Three-way Relaying Systems

Khoiril Anwar and Tad Matsumoto

Information Theory and Signal Processing Lab., School of Information Science,
Japan Advanced Institute of Science and Technology (JAIST) 1-1 Asahidai, Nomi-shi, Ishikawa, 923-1292 Japan
E-mail: {anwar-k,matumoto}@jaist.ac.jp

Abstract—This paper proposes the utilization of side information (SI) received from the nearest node in the network structure of three-way relaying systems. The SI is exploited by the iterative spatial demapping (ISM) to help the detection on the superposition symbols received by the relay, where multiple access scheme is used to increase the spectrum efficiency. Surprisingly, it is found that the side information does not necessarily improve the performance due to the intersection point between the two curves of Extrinsic information transfer (EXIT). EXIT analysis confirmed that more densely doping rate should be utilized when SI is exploited in the three-way relaying system. The potential application of this structure is for disaster area communication as well as satellite communication systems.

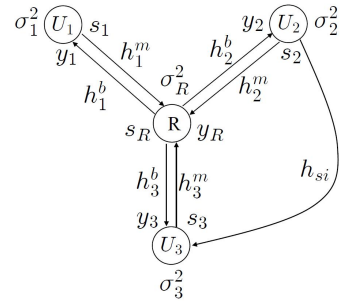

Fig. 1. Structure of three-way relay with side information from user U_2 .

I. INTRODUCTION AND SYSTEM MODEL

In [1] and [2], we have introduced the source correlation exploitation which is then utilized at the receiver via the vertical iteration to have additional gain. The two success keywords are: (1) the update function of log-likelihood ratio (LLR) and (2) the use of doped accumulator. These keywords is then useful for other network structure such as three-way relaying systems [3]. This paper extend the excellent results of [3] by utilizing side information (SI) available at the neighboring nodes.

II. PROPOSED SIDE INFORMATION UTILIZATION

The proposed SI utilization in three-way relaying system is shown in Fig. 2, where the output of the direct link is used as input for the same decoder in the broadcast (BC) mode.

III. EXIT ANALYSIS

Results on EXIT analysis is shown in Fig. 3. Curves (a)-(e) are ISM demapper curve plotted at SNR = 3 dB. Curves (a)-(d) are drawn with doping rate $Q = 4$, where curve (a) is obtained with mutual information of the SI $MI=1$. However at SNR = 1 dB, this curve intersect with the decoder as indicated by curve (d). With the availability of SI, it is proposed the use of doping rate $Q = 1$ as shown by curve (e), where the EXIT tunnel is kept open until (1,1) mutual information point.

IV. CONCLUSIONS

It is found that the utilization of side information does not necessarily helpful without careful consideration of the other parameters. EXIT chart help the optimal doping rate when SI is considered to utilized. It is due to the shaping of ISM demapper curve changed drastically to be almost flat. As a consequence higher doping rate must be optimized to avoid intersection of two EXIT curve which cause error degradation of the system.

REFERENCES

- [1] K. Anwar and T. Matsumoto, "Accumulator-assisted distributed turbo codes for relay system exploiting source-relay correlation," *IEEE Communications Letters*, vol. 16, no. 7, pp. 1114–1117, July 2012.
- [2] —, "Spatially concatenated coded with turbo equalization for correlated sources," *IEEE Trans. Signal Processing*, vol. 60, no. 10, pp. 5572–5577, October 2012.
- [3] —, "Three-way relaying systems using iterative spatial demapping," in *7th International Symposium on Turbo Codes and Iterative Information Processing (ISTC)*, 2012, pp. 96–100.

This research is supported by the Japan Society for the Promotion of Science (JSPS) Grant under the Scientific Research KIBAN KENKYU (B) No. 25289113.

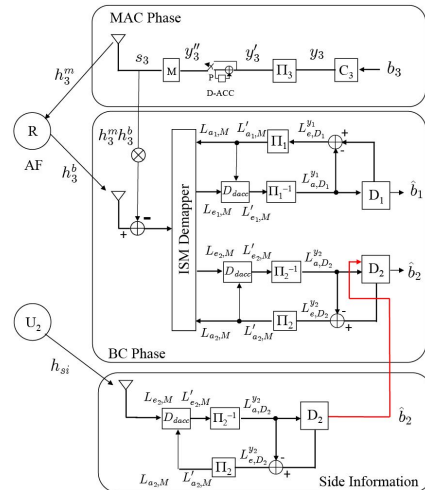

Fig. 2. Side information exploitation at user U_3 .

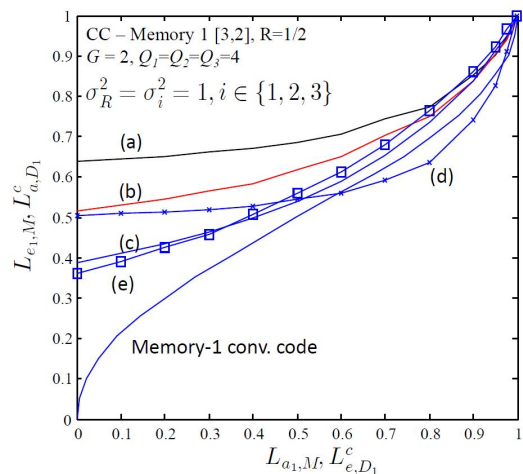

Fig. 3. EXIT chart of ISM demapper and Decoder of user U_1 .