

Title	Performance analysis of mixture of half-duplex and full-duplex wireless networks using network coding
Author(s)	NGUYEN, Minh Dat; LIM, Yuto; TAN, Yasuo
Citation	IEICE Technical Report, 117(426): 115-120
Issue Date	2018-01-23
Type	Journal Article
Text version	publisher
URL	<a href="http://hdl.handle.net/10119/15502">http://hdl.handle.net/10119/15502</a>
Rights	Copyright (C) 2018 The Institute of Electronics, Information and Communication Engineers (IEICE). Minh Dat NGUYEN, Yuto LIM, and Yasuo TAN, IEICE Technical Report, 117(426), 2018, 115-120.
Description	

# Performance Analysis of Mixture of Half-duplex and Full-duplex Wireless Networks using Network Coding

Minh Dat NGUYEN Yuto LIM and Yasuo TAN

School of Information Science, Japan Advanced Institute of Science and Technology (JAIST)  
1-1 Asahidai, Nomi, Ishikawa, 923-1292 JAPAN  
Email: {datnm, ylim, ytan}@jaist.ac.jp

**Abstract** The mixture of full-duplex (FD) and half-duplex (HD) wireless networks and its solutions have been studied to improve the medium access control (MAC) performance. Especially, the header snooping is one of the most effective solutions to achieve the high throughput. Besides, one of the solutions that can significantly enhance the throughput is network coding. The effectiveness of network coding has been extensively studied in many research. Accordingly, the paper aims to propose a new MAC scheme for the mixture of HD and FD wireless network using network coding. This paper investigates the node combination from a network topology and evaluates the performance of the proposed MAC scheme in terms of saturation throughput and the effectiveness of network topology.

**Keywords** Half-duplex, full-duplex, MAC protocol, header snooping, network coding.

## 1. INTRODUCTION

Nowadays, the explosive increase in the number of wireless devices and the high demands of communication performance have created a trend of new techniques in wireless networks. To catch up with those requirements, the wireless full-duplex (FD) technology and network coding (NC) technique are attracted by many researchers, because they can significantly improve the throughput of system. In these research fields, there still exist a few problems that related to hidden terminal problem as well as challenge for MAC protocol. To overcome these problems, many research have already been studied. However, the performance of combination of mixture of HD and FD technology and NC technique needs to be considered more explicitly.

The half-duplex (HD) is a wireless technology in which a wireless transceiver can either transmit or receive signals in a given bandwidth but not both at the same time. Meanwhile, the full-duplex (FD) technology can double spectrum efficiency by simultaneous transmission and reception on the same frequency and time resource. In addition, the FD also helps to reduce end-to-end packet delay and improve network efficiency, the FD is widely considered as one of the promising techniques in 5G systems. The mixture of HD and FD wireless networks is combination of HD and FD nodes into the wireless network system. The aim of this proposition is to improve the end-to-end throughput of system. The most important things to achieve this scheme are related to a new MAC protocol and the hidden terminal problem, which need to be solved

completely, because they directly affect to the performance of wireless network system.

Network coding (NC) is a recent field in information theory that was described in [1]. This technique is essentially a mathematical operation, which is exclusive-OR (XOR) applied to intermediate nodes between source node and destination node. Instead of simply forwarding data, intermediate nodes may recombine several input packets into one or several output packets. In recent years, this is of interest to researchers because of its benefits in the potential throughput improvements.

Figure 1 shows the basic of network coding method or XOR operation for three nodes with assumption that the NC scheme is applied at node R. During the time slot 1 and time slot 2, the message {a} and {b} are sent from node A and B respectively. When node R has received the packets from both the nodes A and node B, it will combine them together with XOR operation  $\{a \oplus b\}$  and broadcasts it as one message towards node A and node B.

The outline of this paper is as follows. Section 2 is presented the background of system model with three nodes by combination of HD and FD nodes for both header snooping (SN) and XOR mechanisms. Besides, the related works and motivation are described. Next, Section 3 is main contribution with new MAC protocol called IFDMA protocol is discussed. Moreover, the scheme of transmission and numerical analysis are presented to calculate the saturation throughput of system models. Section 4 is simulation setting and evaluation results of system model. Finally, Section 5 is conclusion of this paper and discussion about future works.

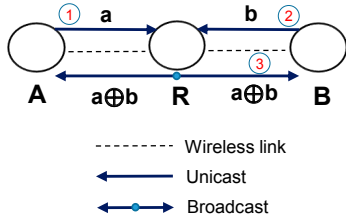

Fig. 1: Basic of Network Coding.

## 2. BACKGROUND AND MOTIVATION

### 2.1. System Model

Figure 2 demonstrates the transmission mode of multiple access (MA) for system model of mixture of HD and FD wireless networks. There are three nodes by combination of HD node and FD node with FD node can be transmission Tx, reception Rx simultaneously. In this figure, node AP is within the transmission range of node A and B, while node B is outside the transmission range of A and vice versa. In other words, node A and B are hidden nodes each other. Node AP is applied the FD-MAC protocol.

### 2.2. Header Snooping

Figure 2a illustrates the header snooping (SN) mechanism. There are two potential actions for FD node. First, node AP starts a new reception session, while transmitting. Let us assume that node AP is transmitting to node A, when node B initiates the transmission of packet. Then node AP has to estimate the channel between node B and itself so as to decode node B's packet. Second, node AP starts a new transmission session, while receiving. When node AP has already commenced receiving a packet from node A and intends to send a packet to node B.

### 2.3. XOR Network Coding

Figure 2b indicates the relay-based XOR operation. Firstly, node AP sends the RTS frame to node A and B. After that, node A and B send the CTS frame to node AP to realize that the channel is free and already for transmission. Also, node A and B have packet for transmission to node AP. When node AP receives two packets from node A and B, it will combine them together by XOR calculation and then broadcasts the encoded packet to both node A and B. Node A and B receive that packet and decode to get the expected packet.

Figure 2c demonstrates the source-based XOR operation. The first, node A sends the RTS frame to node AP and at that time node AP send its RTS frame to node B. Then node AP and node B send the CTS frame to node A and AP respectively. Node A and B already have packet to send to node AP. When node AP receives two packets from node A and B, it will combine them together with the XOR operation and then broadcasts the encoded packet to both node A and B. Node A and B receive that packet and decode to obtain the expected packet.

## 2.4. Related Works

The problems that related to hidden terminal problem and MAC protocol as well as the operation of NC scheme for FD wireless networks were discussed in many research.

Firstly, the effects of hidden terminal problem were described in [2]. A. Tsertou *et al.* determined the conditional collision probability with states of wireless node based on Markov Chain model and then calculated the transmission probability and saturation throughput. Next, the FD MAC solutions for hidden terminal problem were discussed in [3], [4] with three mechanisms, including shared random backoff (SRB), header snooping (SN) and virtual contention resolution (VCR). This MAC frame format was based on IEEE 802.11 packet structure. It just proposed a new FD header with a few specific fields for above mechanisms. These analysis and techniques were analyzed and presented in previous study for mixture of HD and FD wireless network considering hidden terminal problem [5]. The previous study also explicitly extended and analyzed with three states of wireless node, including {success, collision, freeze}. In this paper, [5] is used as a preliminary study and the SN mechanism is focused to analyze the performance of mixture networks.

Besides, the concept physical layer network coding (PNC) was described in [6]. It presented a scheme in which the number of time slots to be reduced. Based on that, the PNC operation was applied in many research for FD MAC protocol using NC scheme. In [7], S. Tedik *et al.* proposed a practical network code for wireless two-way relay channel where all nodes communicate in FD mode. In addition, the NC scheme for multiple access FD relay was described in [8]. This scheme used the XOR operation at the relay node and the iterative decoding at the destination. These research are referred to model and combine XOR operation into mixture network.

## 2.5. Motivation

To analyze the performance of these system models, this paper revisits the previous research work [2], [5] with the effects of hidden terminal problem to performance of system and reviews the MAC protocol design for FD technique is as follows in [3], [4].

Moreover, this paper also investigates the node combination from a network topology between mixture of HD and FD with SN technique and XOR operation in network coding and then evaluates the performance of the proposed MAC scheme in terms of saturation throughput.

Therefore, the expected outcomes are to show the effectiveness of topology combination of SN and XOR operation in the improvement of saturation throughput. The objective of this paper is to propose a new MAC scheme for mixture of HD and FD wireless networks not only combining NC algorithm, but also solving the hidden terminal problem of wireless network. Thus, this research will open a new way to continue solving the remains of problems and improve the performance of wireless network system.

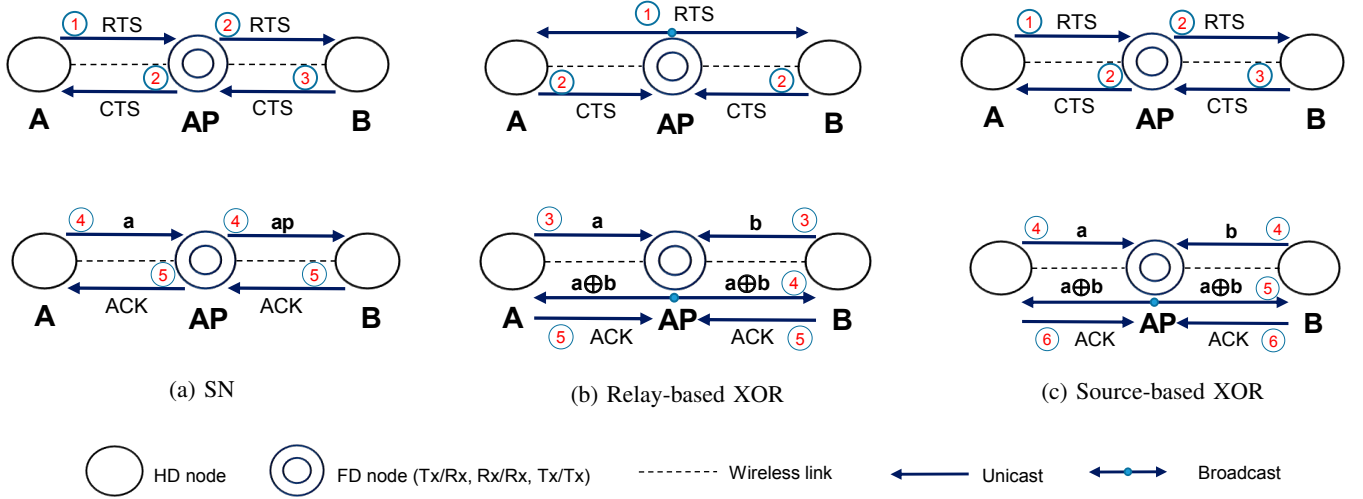

Fig. 2: Transmission mode of MA methods.

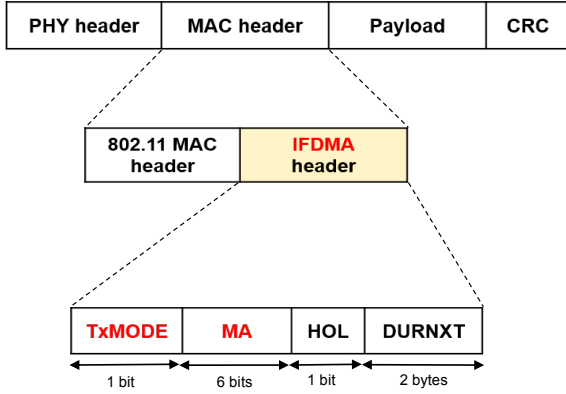

Fig. 3: Structure of proposed MAC frame format.

### 3. PROPOSED MAC PROTOCOL

The system model and scheme of multiple access methods of mixture of HD and FD wireless networks with SN and XOR operation are illustrated in Section 2. To evaluate the performance as well as the effectiveness of these methods, this part will present the new protocol to operate the MA methods for MAC protocol and the derivation of conditional collision probability and saturation throughput for evaluations.

#### 3.1. IFDMA Protocol

As illustrated in [3], base on IEEE 802.11 packet structure, the structure of FD MAC frame was proposed for three mechanisms, including shared random backoff, header snooping and virtual contention resolution. The FD-MAC was described for the more popular use case of infrastructure mode of 802.11 which does not use RTS/CTS. To improve that, based on RTS/CTS mechanism, this paper analyzes and applies to both

SN and XOR operation. Especially, the multiple access (MA) control protocol will be determined in this MAC protocol.

Figure 3 demonstrates the structure of proposed MAC frame format with integrated FD and multiple access (IFDMA) control protocol.

- TxMODE: Mode to consider the HD or FD
- MA: Multiple Access, considering HD, FD, XOR or SN procedure
- HOL: Head-of-Line, indicating the next packet in the buffer is for the destination of the current packet
- DURNXT: Duration of next packet, and is useful when  $HOL = 1$

The HOL field is used to snooping for next packet with the destination (DA) determined. The MA is to indicate the packet which is transmitted for processing of HD, FD, XOR or SN, especially usefulness for XOR and SN mechanisms. They help to distinguish the function of HD, FD node. The DURNXT is useful for estimation the time for FD exchange.

#### 3.2. Modeling and Analysis

In previous study, the conditional collision probability with three states {success, collision, freeze} was discussed based on the Markov Chain approach. First, based on the RTS/CTS mechanism, the time of successful transmission  $T_s$  is defined in Fig. 4 with three cases,  $T_s^{SN}$  for mixture of HD and FD transmission,  $T_s^{XOR_r}$  and  $T_s^{XOR_s}$  for XOR relay-based and source-based respectively. The time of transmission is operated based on MAC protocol that was described in previous section.

$$\begin{aligned}
 T_s^{SN} &= 2RTS + CTS + DATA + ACK + 4SIFS + DIFS \\
 T_s^{XOR_r} &= RTS + CTS + 2DATA + ACK + 4SIFS + DIFS \\
 T_s^{XOR_s} &= 2RTS + CTS + 2DATA + ACK + 5SIFS + DIFS
 \end{aligned} \tag{1}$$

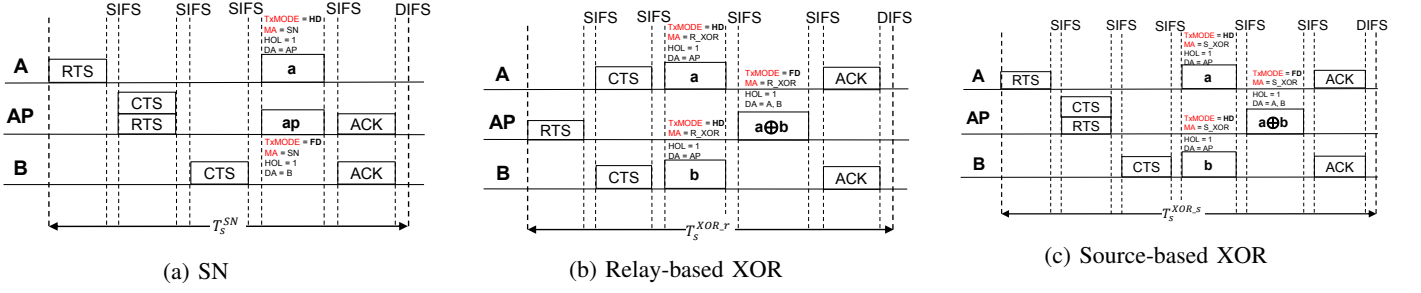

Fig. 4: The frame exchange in the time of successful transmission.

Besides, the slot has the length of a collided transmission,  $T_c = \text{RTS} + \text{DIFS}$ , for all stations. When the node is in backoff time, it has slot time length  $\sigma$ , is  $20\mu\text{s}$ .

Moreover, to easily analyze as well as evaluate, this paper proposes a definition for HD and FD node as bit “0” and “1” respectively. Therefore, the topology for SN and XOR operation likes “0 - 1 - 0”. To operate the SN or XOR topology, the IFDMA protocol will be analyzed with which function is for MA field.

### 3.3. Numerical Analysis

**3.3.1. Throughput Performance:** This part will show the derivation of throughput performance.

According to the analysis in [5], three states of wireless node, including {collision, success, freeze} that were considered, the conditional collision probability  $p$  is calculated as follows:

$$p = \frac{2p'}{1 + p'} \quad (2)$$

where  $p'$  is probability that the receiver observes a collision.

The throughput performance of wireless network was presented by ( $S$ ), which is defined as the number of packets transmitted during a specific period of time divided by the duration of that period.  $S$  is calculated as follows:

$$S = P_T \cdot \frac{(1-p)L}{(1-p)L + pC} \cdot \frac{1}{L} \quad (3)$$

where

- $P_T$ : transmission probability
- $p$ : conditional collision probability
- $L$ : successful period
- $C$ : collision period

For the details of calculation were described in [5].

Moreover, to quantify the amount of variation of throughput, we calculate the standard deviation as follows:

$$\sigma = \sqrt{\frac{\sum_{i=1}^N (S_i - \bar{S})^2}{N-1}} \quad (4)$$

where  $\sigma$  is standard deviation,  $N$  is number of data,  $S_i$  is  $i$ -th throughput and  $\bar{S}$  is mean of throughput.

A low standard deviation indicates that the throughput points tend to be close to the average one, while a high standard deviation indicates that the throughput points are spread out over a wider range of values.

**3.3.2. The Effect of Interference:** In this part, the influence of interference to performance of wireless network system will be discussed. This problem was mentioned in many research. The formulas and calculation as follows:

- Channel gain between node  $i$  and node  $j$  is depend on the Log-distance pathloss model,  $PL_0$  is assumed as Friis free space model

$$PL_{ij} = PL_0 + 10 \cdot \alpha \cdot \log_{10} \left( \frac{d_{ij}}{d_0} \right) - W_{ij} + X_\sigma \quad (5)$$

where  $PL_0 = 20 \cdot \log_{10}(d_0)$

- Power ratio between node  $i$  and node  $j$  is

$$G_{ij} = \frac{1}{10^{\left(\frac{PL_{ij}}{10}\right)}} \quad (6)$$

- Signal to interference and noise ratio at node  $j$  is

$$SINR_{ij} = \frac{G_{ij}P_i}{\eta_j B + \sum_{k \in \mathcal{X}, k \neq i} G_{kj}P_k} \quad (7)$$

- Rate of transmission from node  $i$  and node  $j$  is

$$R_{ij} = B \log_2 \left( 1 + \frac{1}{I} SINR_{ij} \right) \quad (8)$$

where

- $P_i$ : transmit power of node  $i$
- $d_{ij}$ : distance between node  $i$  and node  $j$
- $W_{ij}$ : wall attenuation from node  $i$  to node  $j$
- $X_\sigma$ : shadowing attenuation
- $G_{ij}$ : channel gain from node  $i$  to node  $j$
- $\eta_j$ : noise of node  $j$
- $SINR_{ij}$ : SINR from node  $i$  to node  $j$
- $R_{ij}$ : achievable rate from node  $i$  to node  $j$
- $B$ : channel bandwidth

After the rate of transmission or channel rate is evaluated, it needs to be converted to the data rate of MAC rate for calculation the throughput of MAC system as follows the standard IEEE 802.11g.

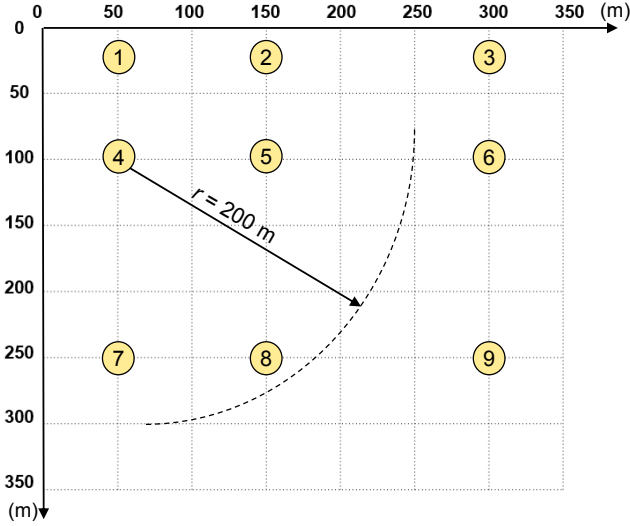

Fig. 5: Scenario of Simulation.

## 4. NUMERICAL SIMULATIONS

### 4.1. Simulation Scenario and Setting

The scenario for simulation is illustrated in Fig. 5 with 9 nodes and the place for each node is controlled inside the area (350m  $\times$  350m). The hidden terminal problem is determined by transmission range of each wireless node. In this case, it equals 200m and same for all nodes.

TABLE I shows the parameters for scenario setting with the detail of size, number of nodes, transmission range and the other parameters for interference effects. The formulas of parameters are presented in previous section.

Besides, TABLE II shows the parameters of simulation when precessing data transmission. The standard is followed as IEEE 802.11g.

TABLE I: Simulation parameters of scenario model.

Parameter	Value
Size	350 m $\times$ 350 m
Number of node	9
Transmission range ( $r$ )	200 m
Minimum distance between nodes ( $d_o$ )	10 m
Maximum transmit power ( $P_{max}$ )	0.2 Watt
Attenuation constant ( $\alpha$ )	3.5
Wall attenuation ( $W_{ij}$ )	0 dB
Shadowing parameter ( $X_\sigma$ )	8 dB
Noise level ( $\eta$ )	- 174 dBm
Channel bandwidth ( $B$ )	10 MHz
Value depends on the choice of coding and modulation parameters, and the BER requirement ( $\Gamma$ )	1

TABLE II: The list of simulation parameters and setting.

Parameters	Values
Packet length (bytes)	[256, 512, 1024, 1536, 2048, 2294]
Contention window	[32, 64, 128, 256, 512, 1024]
Basic rate (Mbps)	[1, 2]
Data rate (Mbps)	[1, 2, 5.5, 11, 6, 9, 12, 18, 24, 36, 48, 54]
PLCP header (bits)	192
MAC header (bits)	272
PHY header (bits)	128
RTS size (bits)	160
CTS size (bits)	112
ACK size (bits)	112
SIFS length ( $\mu$ s)	10
DIFS length ( $\mu$ s)	50
Slot time length ( $\mu$ s)	20
EIFS length ( $\mu$ s)	DIFS + CTS + SIFS

### 4.2. Evaluation Results

The objective of this evaluation is to show the improvement of mixture HD and FD wireless networks using XOR network coding in terms of saturation throughput.

Figure 6 illustrates the comparison of saturation throughput among HD, FD, SN, relay-based XOR(R\_XOR) and source-based XOR(S\_XOR) under the data rate equals 12 Mbps. We can easily recognize that the FD technique obtains the highest throughput, followed by SN, XOR and finally the HD technique gets the smallest one. Especially in XOR operation, the results of R\_XOR are better than S\_XOR operation.

Figure 7, 8 show the comparison of saturation throughput with and without the effect of interference, respectively. In this case, the R\_XOR is evaluated. Each simulation point in the graphs corresponds to the average of throughput with  $CW = 32$ . With the effects of interference, the saturation throughputs are reduced for all techniques and the SN technique gives the highest throughput, followed by IFDMA operation.

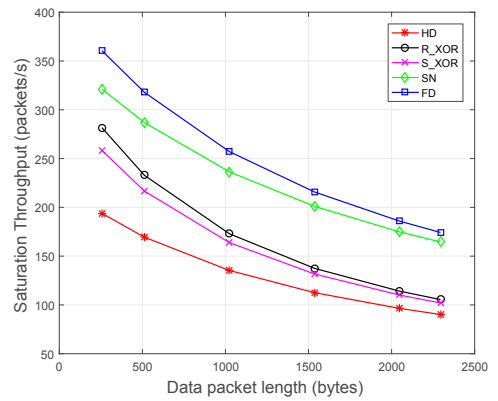

Fig. 6: Comparison of saturation throughput with data rate 12 Mbps.

TABLE III: The Comparison of Throughput.

Technique	Maximum (Mbps)		Average (Mbps)		Standard Deviation (Mbps)	
	Without Inter.	With Inter.	Without Inter.	With Inter.	Without Inter.	With Inter.
HD	1.902	1.699	0.561	0.492	0.419	0.369
FD	3.331	2.957	0.998	0.855	0.752	0.642
R_XOR	2.732	2.141	0.913	0.728	0.572	0.460
S_XOR	2.544	1.916	0.858	0.690	0.538	0.434
SN	3.110	2.790	1.106	0.957	0.693	0.596
IFDMA (SN+R_XOR)	2.870	2.531	1.056	0.898	0.630	0.531
IFDMA (SN+S_XOR)	2.927	2.657	1.047	0.892	0.617	0.519
IFDMA (R_XOR+S_XOR)	2.418	2.271	0.873	0.729	0.560	0.462

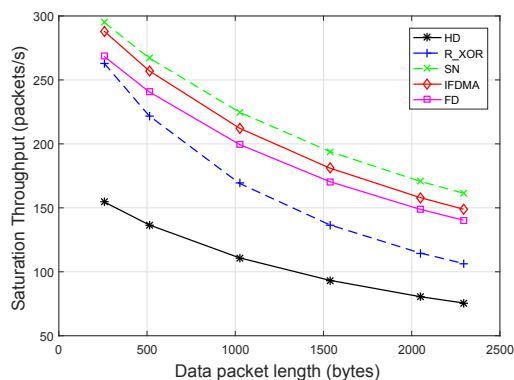

Fig. 7: Comparison of saturation throughput without interference effect.

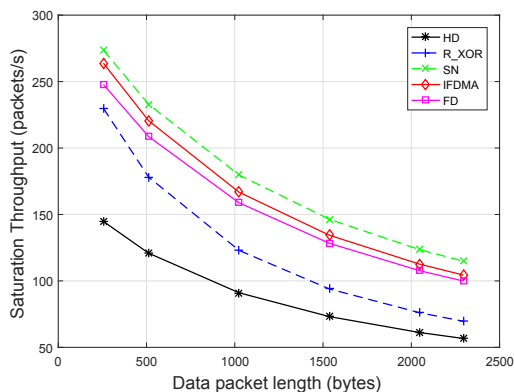

Fig. 8: Comparison of saturation throughput with interference effect.

Besides, TABLE III shows the detail comparison of throughput for all topology cases with packet length equals 512 (bytes). These results also indicate the effectiveness of the IFDMA protocol by combination of SN with R\_XOR and S\_XOR operation.

As a result, we can say that the mixture SN and XOR mechanism, IFDMA is more effective in the improvement in saturation throughput of wireless network system. This is really an advantage of mixture of HD and FD wireless networks using network coding.

## 5. CONCLUSION

In this paper, we have focused on analyzing the mixture of HD and FD wireless networks using network coding by combination of SN and XOR topology. Besides, the influence of interference was considered, which directly affects to performance of wireless network system. In addition, we also discussed the new MAC frame format with considering the multiple access control protocol, IFDMA protocol. The evaluation results were explicitly presented by comparison among various techniques and showed that the IFDMA operation by combination of SN with relay-based XOR (R\_XOR) and source-based XOR (S\_XOR) gives the better saturation throughput compared with HD transmission.

For future works, to evaluate the comprehensive of the IFDMA control protocol for wireless networks, the function of each field inside of IFDMA frame needs to be analyzed more explicitly. Especially, the multiple access control protocol should be discussed in more detail of combination. Besides, the scenario simulation should be extended and consider the random wireless network with the large number of wireless nodes. Also the algorithms for optimization of wireless networks such as topology control management, transmit power control (TPC) should be considered.

## REFERENCES

- [1] R. Ahlswede, N. Cai, S.-Y. Li, and R. W. Yeung, "Network information flow," *IEEE Transactions on information theory*, vol. 46, no. 4, pp. 1204-1216, 2000.
- [2] A. Tsertou and D. I. Laurenson, "Revisiting the hidden terminal problem in a CSMA/CA wireless network," *IEEE Trans. Mob. Comput.*, vol. 7, no. 7, pp. 817-831, 2008.
- [3] A. Sahai, G. Patel, and A. Sabharwal, "Pushing the limits of Full-duplex: Design and Real-time Implementation," 2011.
- [4] Z. Zhang, K. Long, A. V. Vasilakos, and L. Hanzo, "Full-duplex Wireless Communications: Challenges, Solutions, and Future Research Directions," *IEEE Proc.*, vol. 104, no. 7, pp. 1369-1409, 2016.
- [5] Minh Dat NGUYEN, Yuto LIM, and Yasuo TAN, "Mixture of Half-duplex and Full-duplex Considering Hidden Terminal Problem," *IEICE ASN Tech. Rep.*, vol. 117, no. 134, ASN2017-56, pp. 217-222, July 2017.
- [6] S. C. Liew, S. Zhang, and L. Lu, "Physical-layer network coding: Tutorial, survey, and beyond," *Physical Communication.*, vol. 6, pp. 4-42, 2013.
- [7] S. Tedik and G. K. Kurt, "Practical full duplex physical layer network coding," in *IEEE 79th Vehicular Technology Conference (VTC Spring)*, pp. 1-4, May 2014.
- [8] Z. Li, M. Peng, and W. Wang, "A network coding scheme for the multiple access full-duplex relay networks," in *6th International ICST Conference on Communications and Networking in China (CHINACOM)*, pp. 1132-1136, Aug 2011.